

TB16IN-PHO

Basic Installation Instruction V1.0

Dear users, please go through the instructions in detail before the installation. Also, please preserve the manual properly and hand it to the actual operator of the machine.

CNC controllers are precision electronic devices. For the safety of both operators and the machine, please make sure all the tests, installations and adjustments are operated by professional electrical engineering personnel. For the description with “**DANGER**”, “**WARNING**” and “**CAUTION**” in the manual, please read them in detail. If there are any concerns, please contact our branches in various regions. Our professionals are glad to be at your service.

1. Safety Precautions :

Please pay extra attention to the instructions below while operating the product.	
	<ul style="list-style-type: none"> The controller series are designed to control the motor of the machine tool and manage the IO control. Do not touch the internal circuits or components while the controller is powered up. The internal circuit board of the controller is composed of CMOS ICs, which are vulnerable to static electricity. Do not touch the circuit board with your hand before taking precautionary measures.
	<ul style="list-style-type: none"> Please cut off all the external devices when powering up the controller for the first time. The built-in testing PLC program may start the motor immediately after powered up, which might be dangerous for the staffs around. The controller is a precision instrument. Please prevent non-maintenance staff or non-professional electronic control personnel from disassembling the device.
	<ul style="list-style-type: none"> The CNC controller adopts microcomputer design. Please install the controller in a safe area and keep the area clean. Please keep the iron shavings, wires, water, corrosive gas and liquid from the controller to avoid malfunctioning. Storage temperature range: -20°C~60°C Storage relative humidity range: 0%~90% and without condensation. Operating temperature range: -10°C~55°C Please reserve a space of more than 50mm in width for ventilation and heat dissipation. The grounding of the controller and machine tool system is necessary for leakage protection and prevention of lightning strikes. Please ensure the machine tool system are grounded properly before the installation.

Please pay extra attention to the instructions below while operating the product.	
	<ul style="list-style-type: none"> The controller should be installed with a power system operated below 24±20%. If the operating environment provides an unstable voltage source, please apply a voltage stabilizer so that the controller can function properly. Please turn off the power before plugging/unplugging the cables or modifying the wirings to prevent electric shocks and damage of the controller. Please make sure all the terminals are in the correct position during wiring to prevent the controller from damage caused by wiring mistakes.

2. Description :

The Syntec PIO5 dedicated termination board, equipped with 16 independent points optical coupler interface, can be activated by both SINK and SOURCE interfaces, which is able to solve the problems resulted from various input interfaces.

3. Function :

TB16IN-PHO is a newly developed termination board from Syntec, which is compatible with Syntec TB16IN termination board. This termination board can solve the compatibility problems arisen from the difference between SINK and SOURCE interface.

4. Features :

- 24V single power input
- 16 sets of PHOTOCOUPLE terminal input
- applicable for NPN and PNP SENSOR
- Compatible with Current Source and Current Sink

5. Termination board Interface :

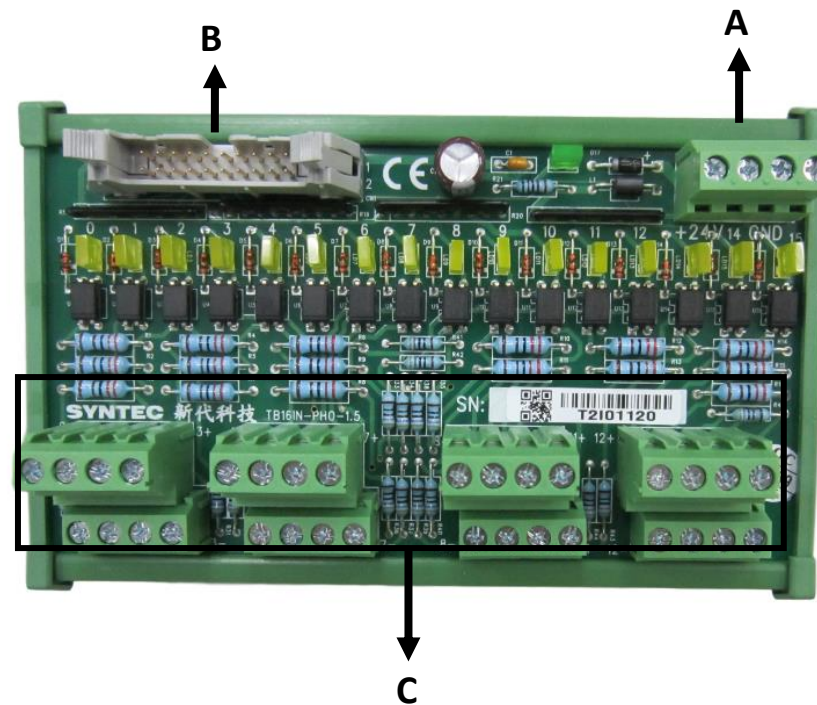

A	Power Input	24V · 1A input
B	X Input Port	I point input
C	Input Port	16 sets of photo coupler input

6. Structure Specifications : (Unit : mm)

(Front view)

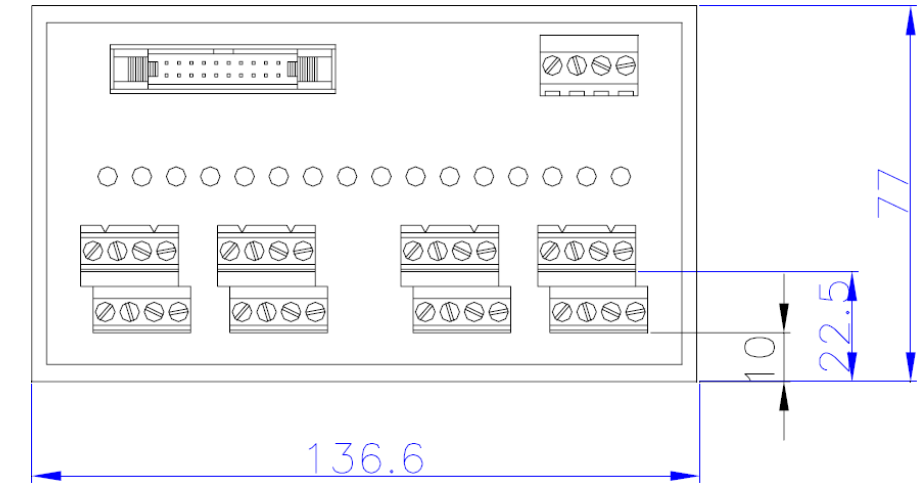

(Side view)

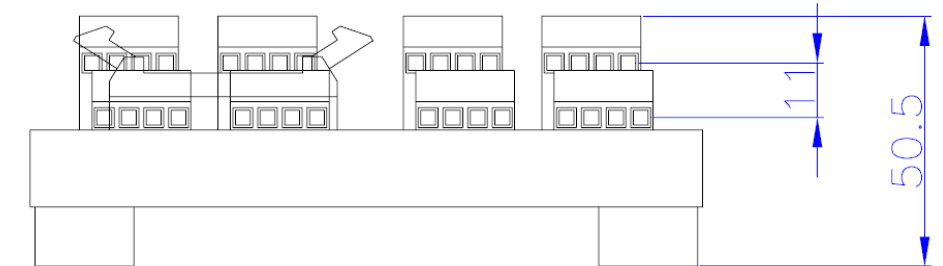

7. Interface Configuration :

Please notice the value and the polarities of voltages.

● CN1 Connector Arrangement

CN1	PIN	SIGNAL	PIN	SIGNAL
	19	IN0	20	IN8
	17	IN1	18	IN9
	15	IN2	16	IN10
	13	IN3	14	IN11
	11	IN4	12	IN12
	9	IN5	10	IN13
	7	IN6	8	IN14
	5	IN7	6	IN15
	3	GND	4	GND
	1	+24V	2	+24V

● 24V INPUT Connector Arrangement

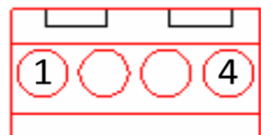
24V INPUT	PIN	SIGNAL
	1	+24V
	2	+24V
	3	GND
	4	GND

● TB1 Connector Arrangement

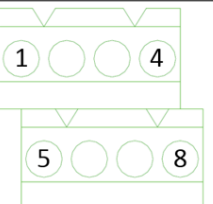
TB1	PIN	SIGNAL	PIN	SIGNAL
	1	IN0+	5	IN0-
	2	IN1+	6	IN1-
	3	IN2+	7	IN2-
	4	IN3+	8	IN3-

● TB2 Connector Arrangement

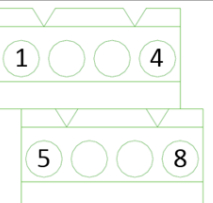
TB2	PIN	SIGNAL	PIN	SIGNAL
	1	IN4+	5	IN4-
	2	IN5+	6	IN5-
	3	IN6+	7	IN6-
	4	IN7+	8	IN7-

● TB3 Connector Arrangement

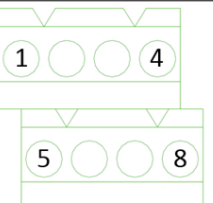
TB3	PIN	SIGNAL	PIN	SIGNAL
	1	IN8+	5	IN8-
	2	IN9+	6	IN9-
	3	IN10+	7	IN10-
	4	IN11+	8	IN11-

● TB4 Connector Arrangement

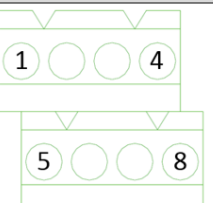
TB4	PIN	SIGNAL	PIN	SIGNAL
	1	IN12+	5	IN12-
	2	IN13+	6	IN13-
	3	IN14+	7	IN14-
	4	IN15+	8	IN15-

8. Basic Wiring Diagram :

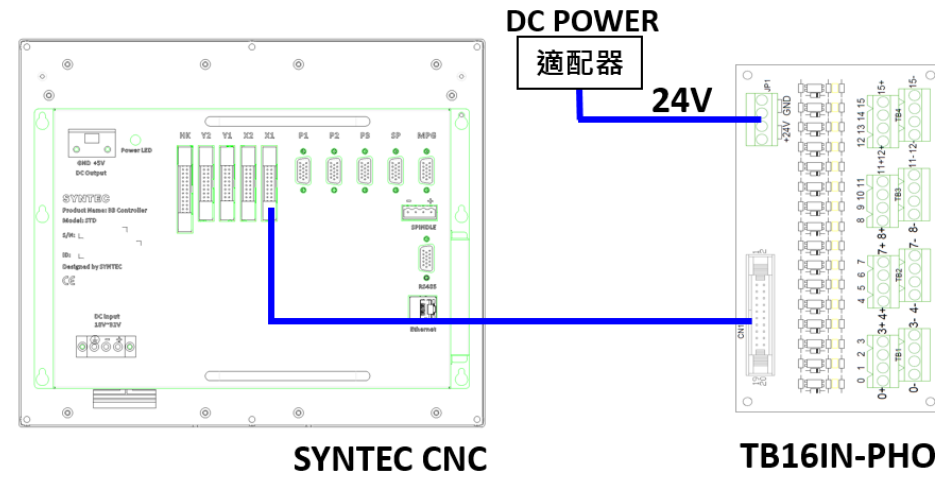

9. Interface Circuit :

INPUT0~15 Input Interface

- PNP SOURCE Interface

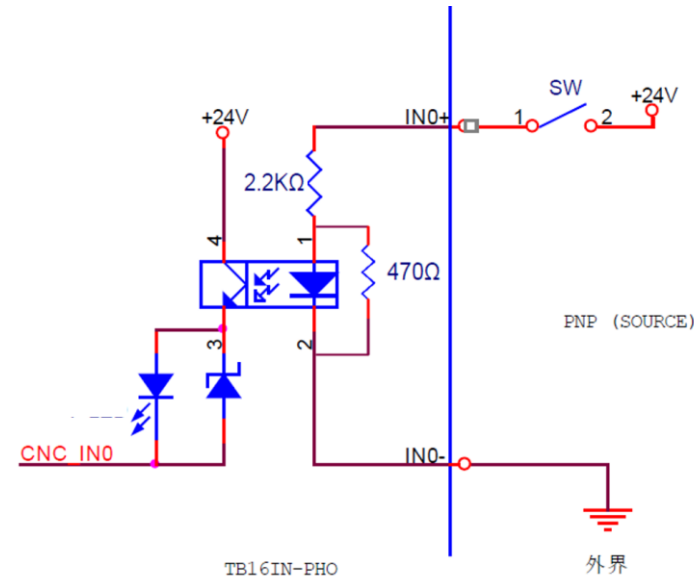

- NPN SINK interface

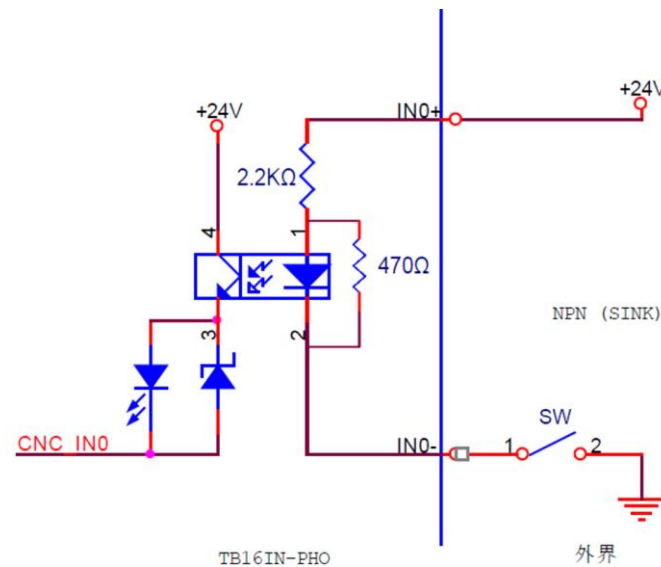

10. Wiring Notifications :

- When using a solenoid valve or other inductive loads, please apply an arc extinguisher or RC voltage dependent resistor RC to ensure the life of the contact points. Advantages of the arc extinguisher:
 - 1) Extend the life of electrical contacts.
 - 2) Reduce the sparks from the contact points.
 - 3) Prevent the inductive loads from interferences caused by back EMF.
 - 4) Restrain the impulse voltage.
- If the server line you are using is not a standard Syntec cable, please check all the terminals and make sure they are connected properly before running a test. Wrong wirings will lead to the controller output command error and cause malfunctioning.
- MPG terminal's +5V output capacity is 200mA and it is only for a single external hand wheel. Do not connect it with other loads or it might cause malfunction due to the lack of drive capacity.
- The external 24V DC power supply used in wiring should be certificated and protective to avoid the malfunction caused by wiring mistakes. (Recommendation standard : fulfill requirements of both EN60950 & UL1950)
- Please crimp or weld the wire connections while doing the wirings.
- In case of the use of Ethernet, to prevent internet congestion and noise, the CAT5e or CAT6 cable are recommended.
- Do not use counterfeit terminal strips. Those terminal strips cannot provide overall protection for the system. The quality is also not guaranteed and prone to cause electrical control problem of the machine tools.
- Grounding Directions:
 - 1) The length of the grounding wire should follow the electrical equipment regulations. The shorter the better.
 - 2) The grounding wire of the controller should be separated from those with large current loading such as electric welders or high frequency motors.
 - 3) Please refer to the pictures below when the controller is grounded with multiple electrical control devices. Do not make it a loop.

